

# Portable Product Displays Revision 1

MOCKUP & NOTES

FRONT

ORIGINAL

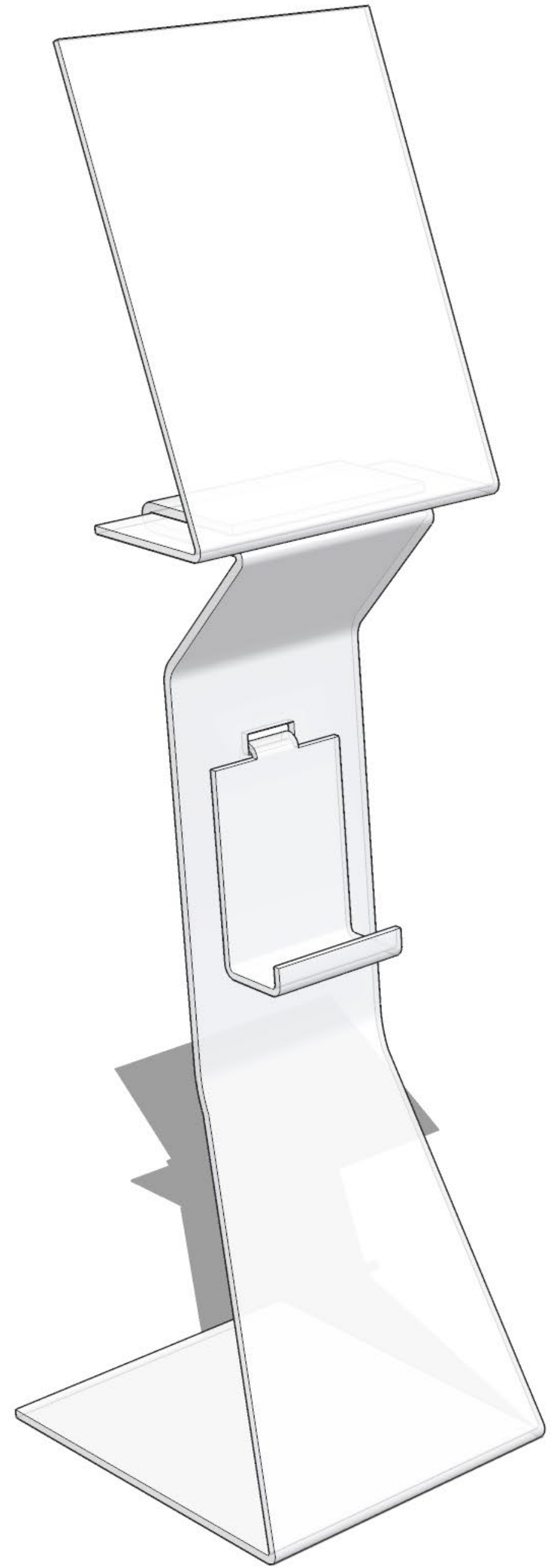

REVISION

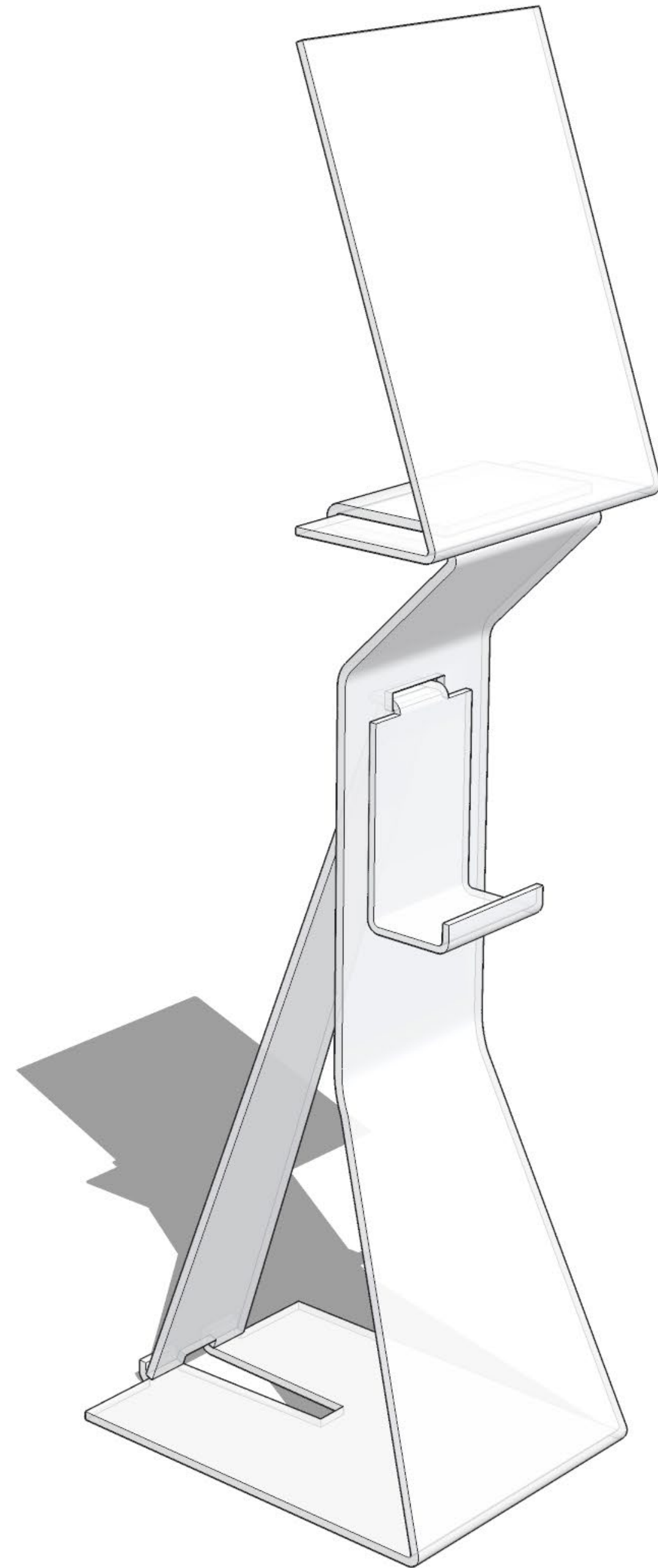

# REVERSE

THE GOAL: prevent the base from flexing during a product demo

Brace maintains tension

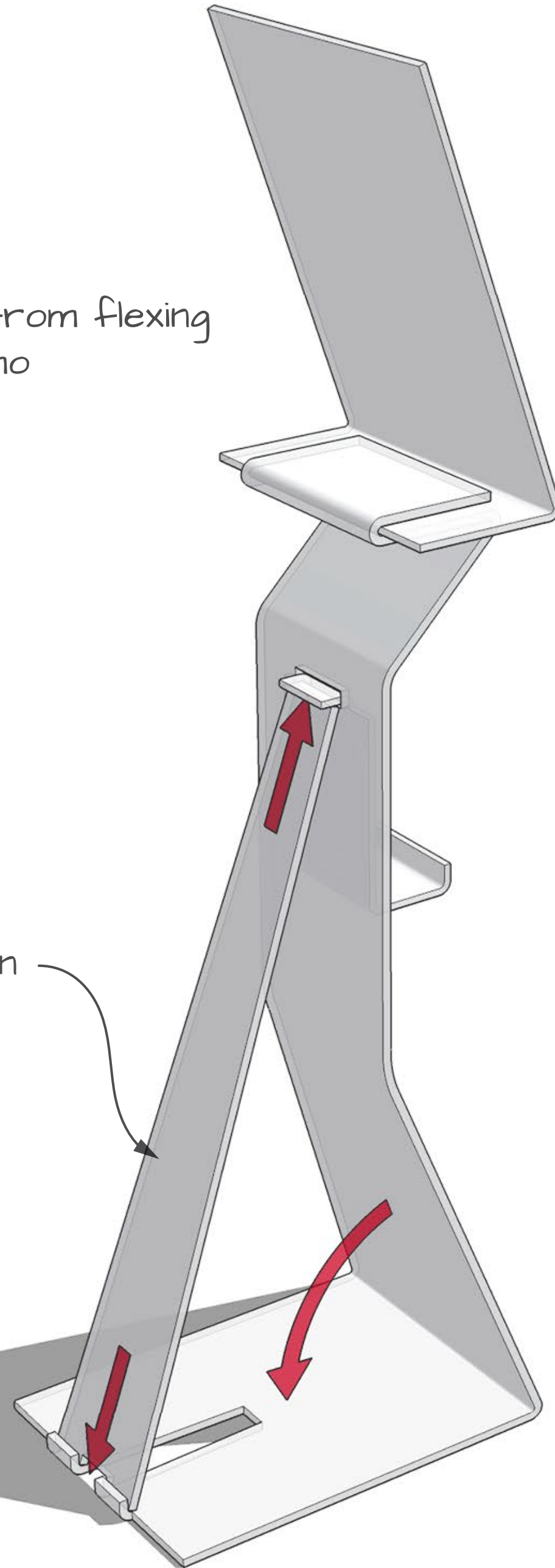

## IMPORTANT:

The following revision(s) depend on the firm tension fit of the Base & Brace w/ mounted product. Dimensions supplied are for reference only. Cut to fit.

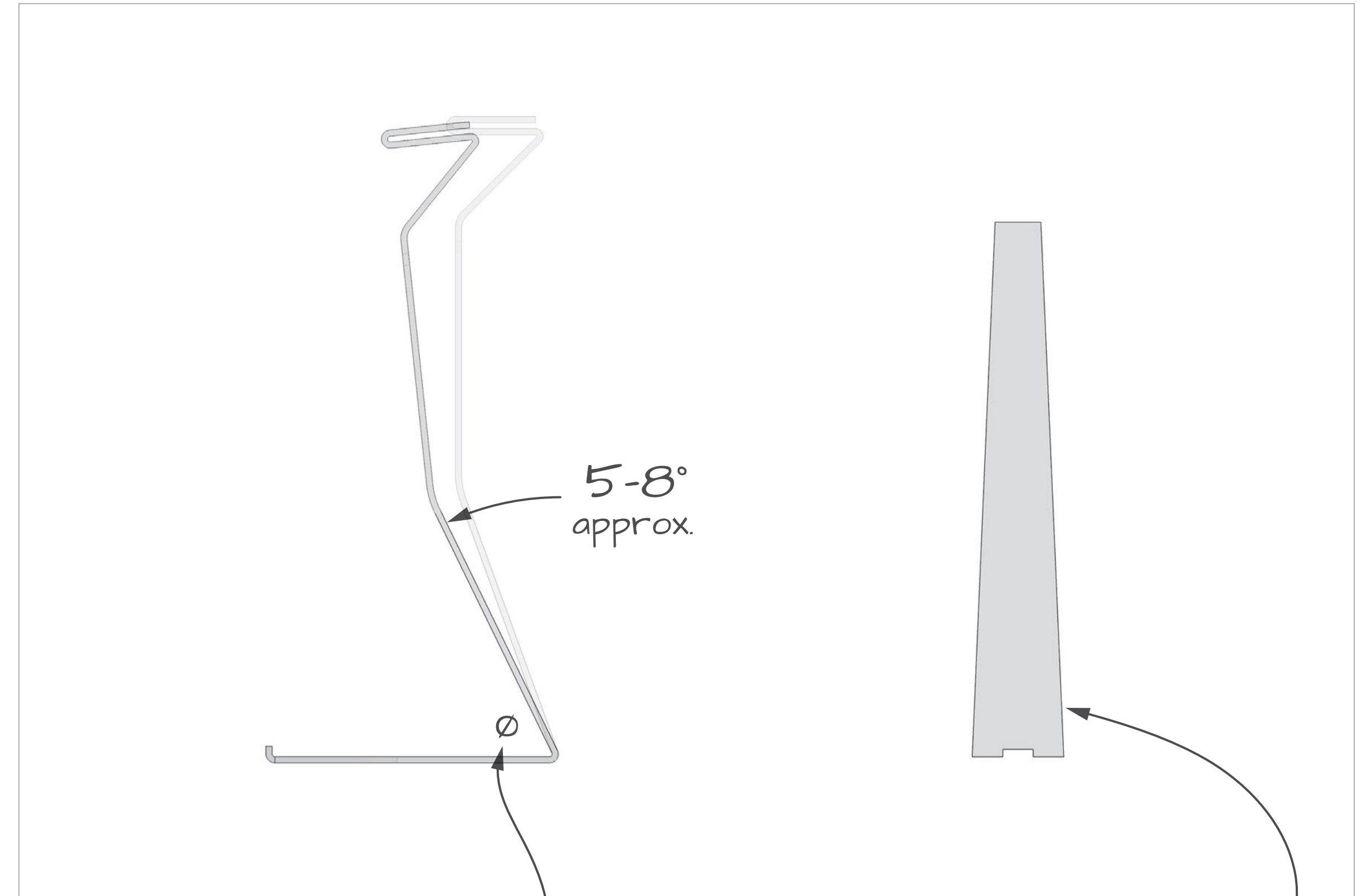

Over-bend the Base, angle  $\phi$ , by 5-8° to create tension

Produce insertable Brace to force  $\phi$  back to normal

# SELL SHEET HOLDER

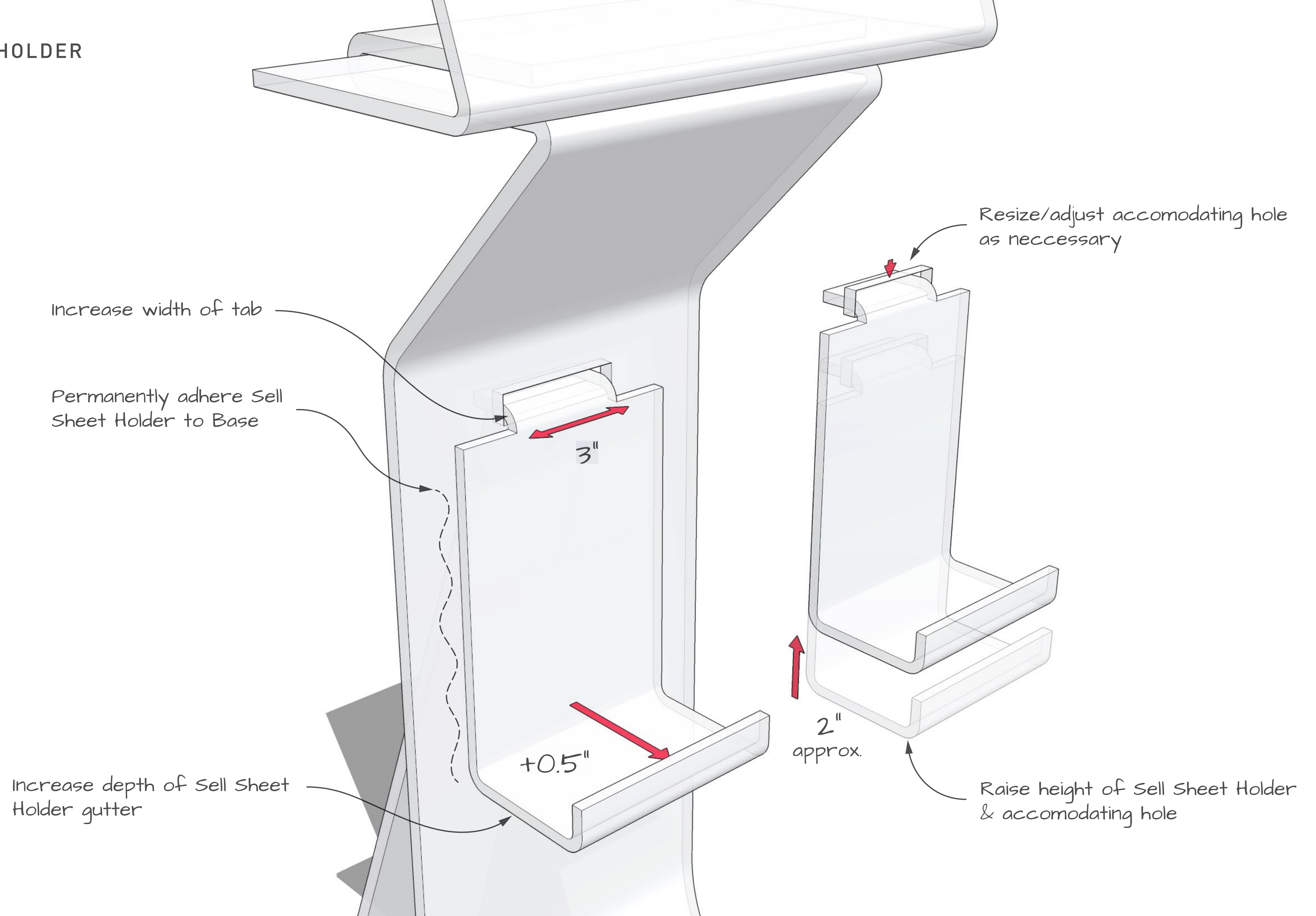



SELL SHEET HOLDER REAR

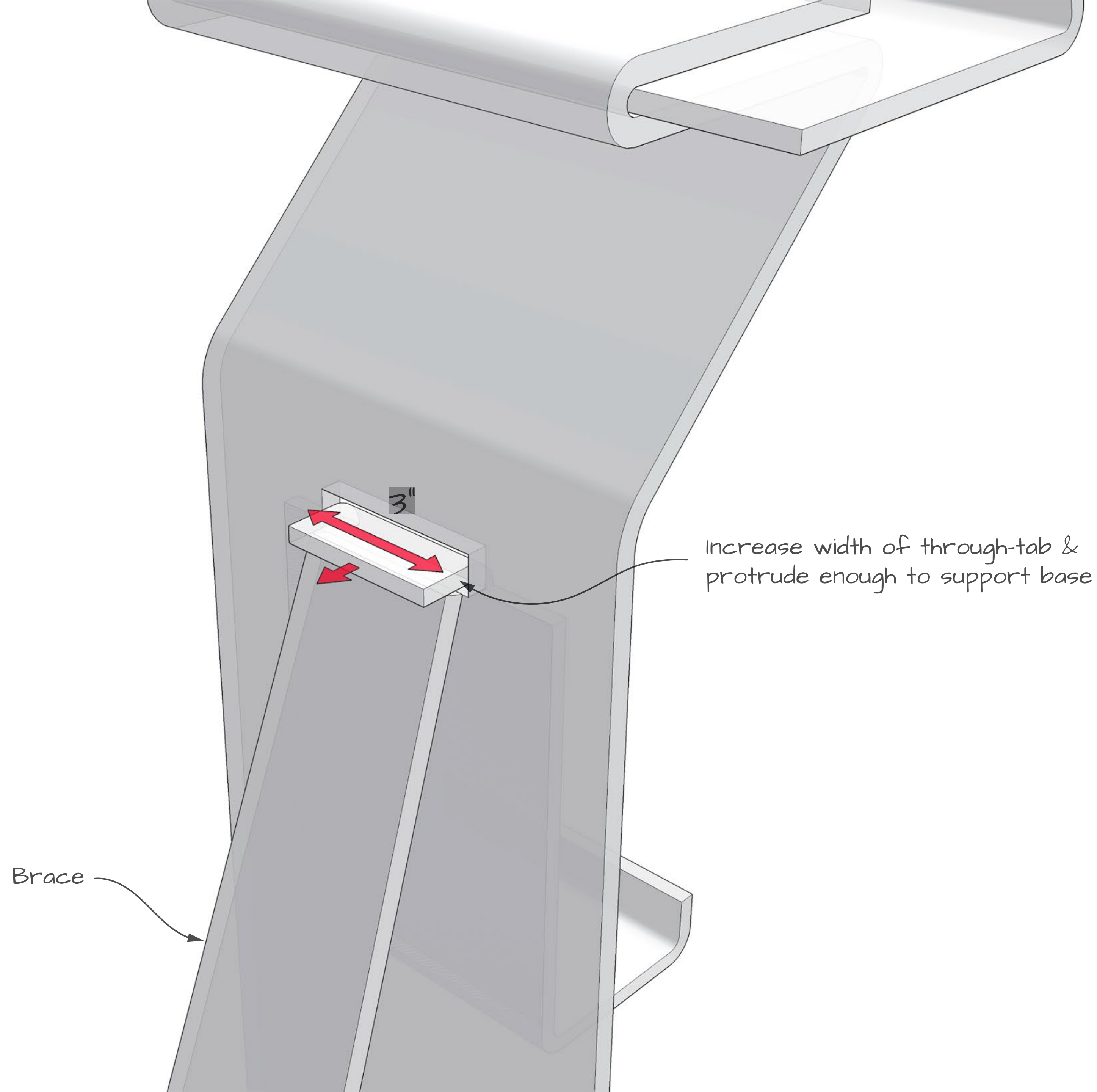

3"

Increase width of through-tab & protrude enough to support base

Brace

# BASE FOOTING

Bend-up tabs on support Brace

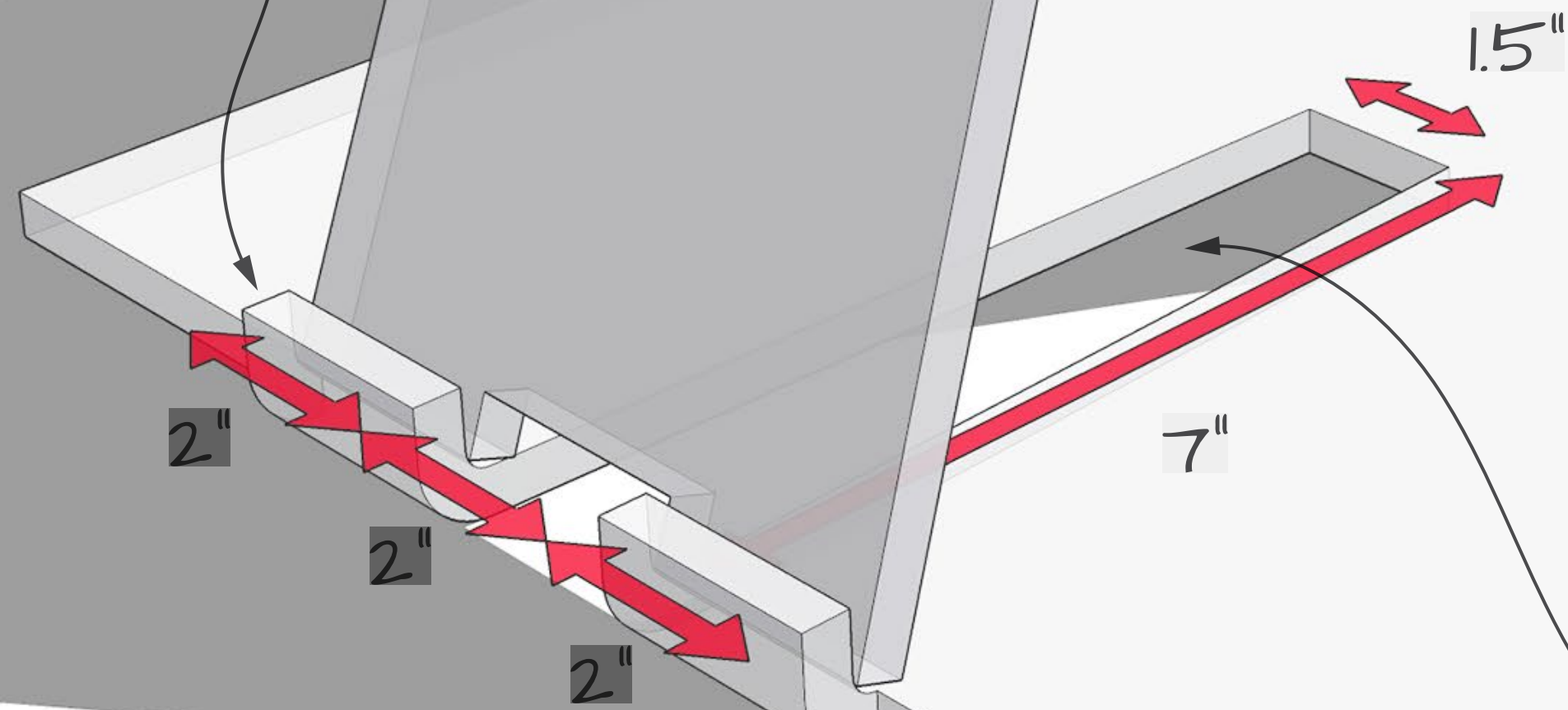

Cut-out void to accomodate footing for roll-up-banners

BRACE

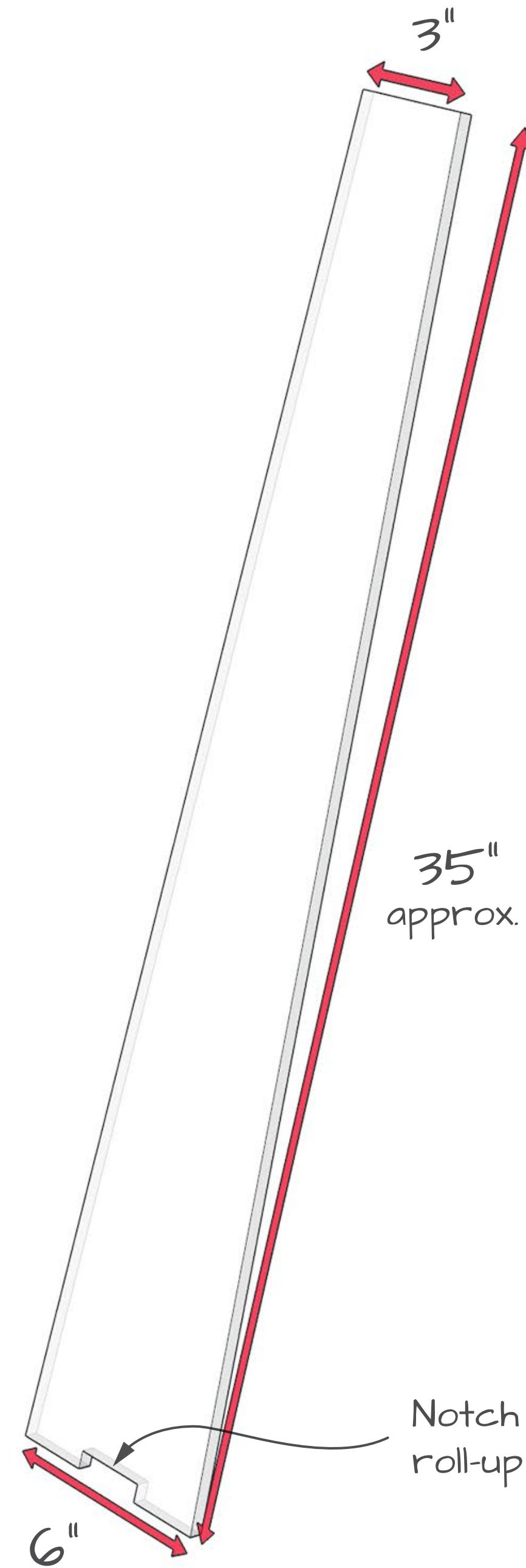
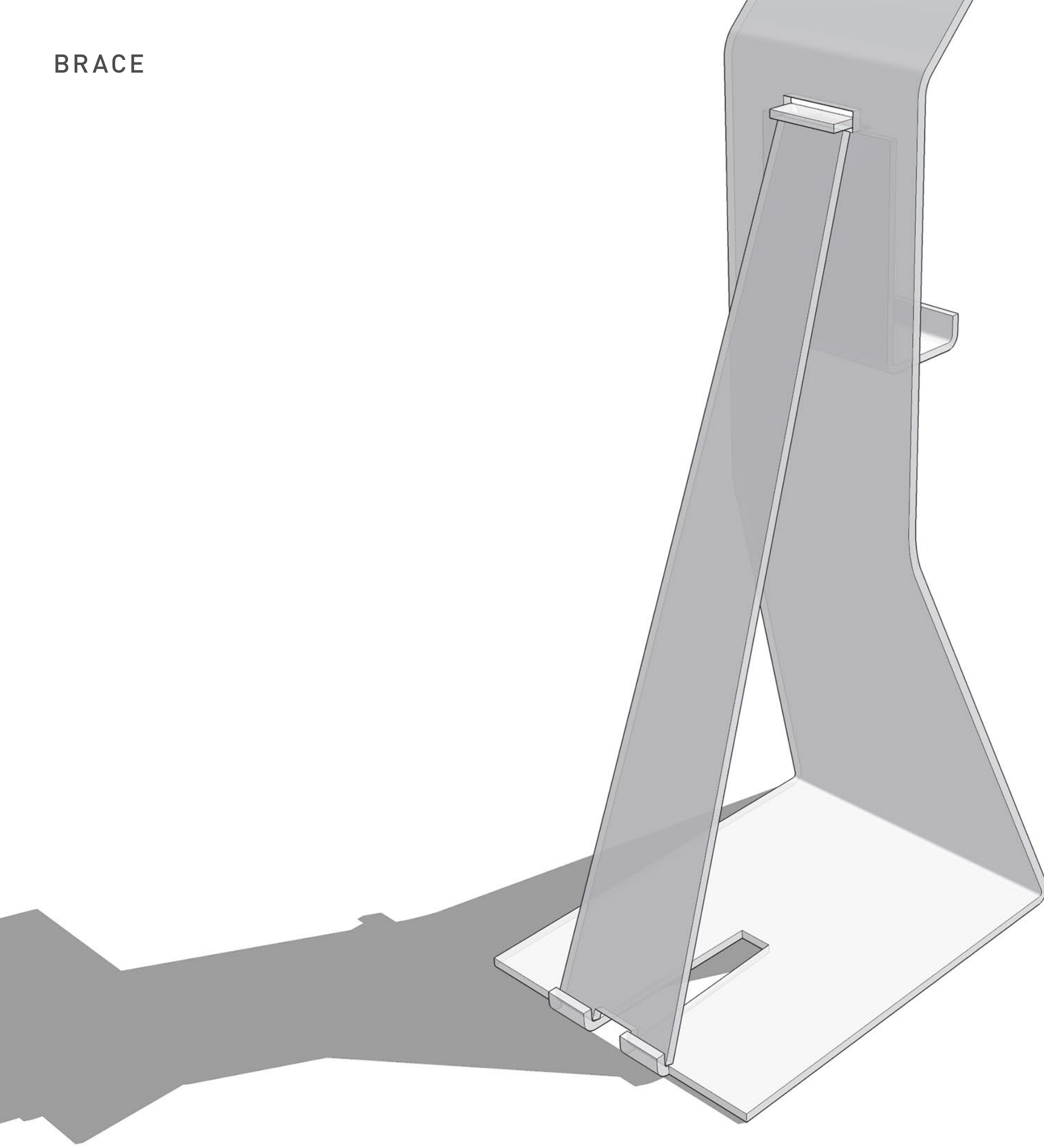

Notch 1/2" to accomodate footing for roll-up banners.



PRODUCT MOUNT REAR

**IMPORTANT:**  
The fit between the Base platform & the Product Mount that was achieved in the prototype was perfect. We're looking at adding clear friction tape to the bottom of the Product Mount(s) for stability.

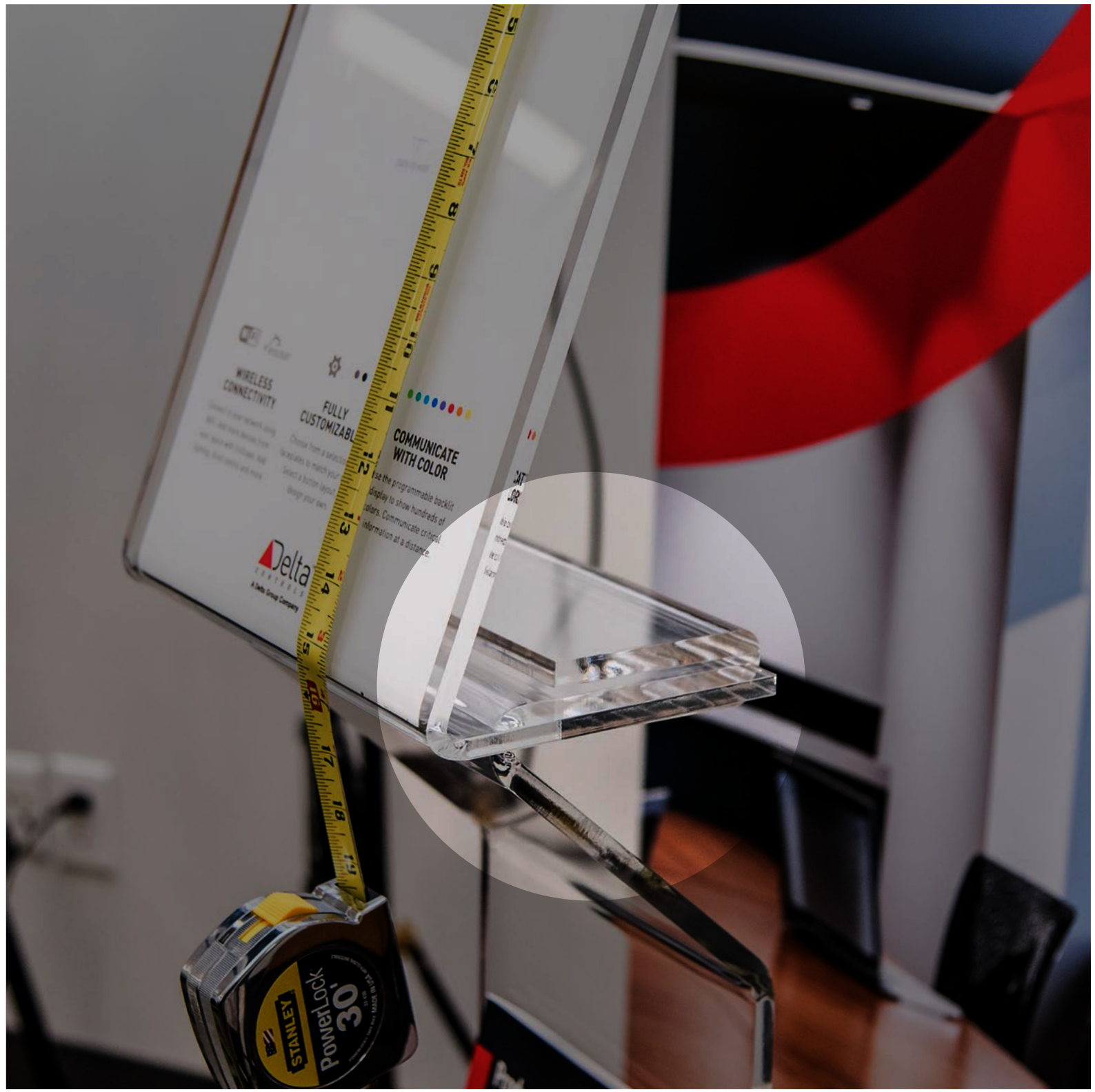
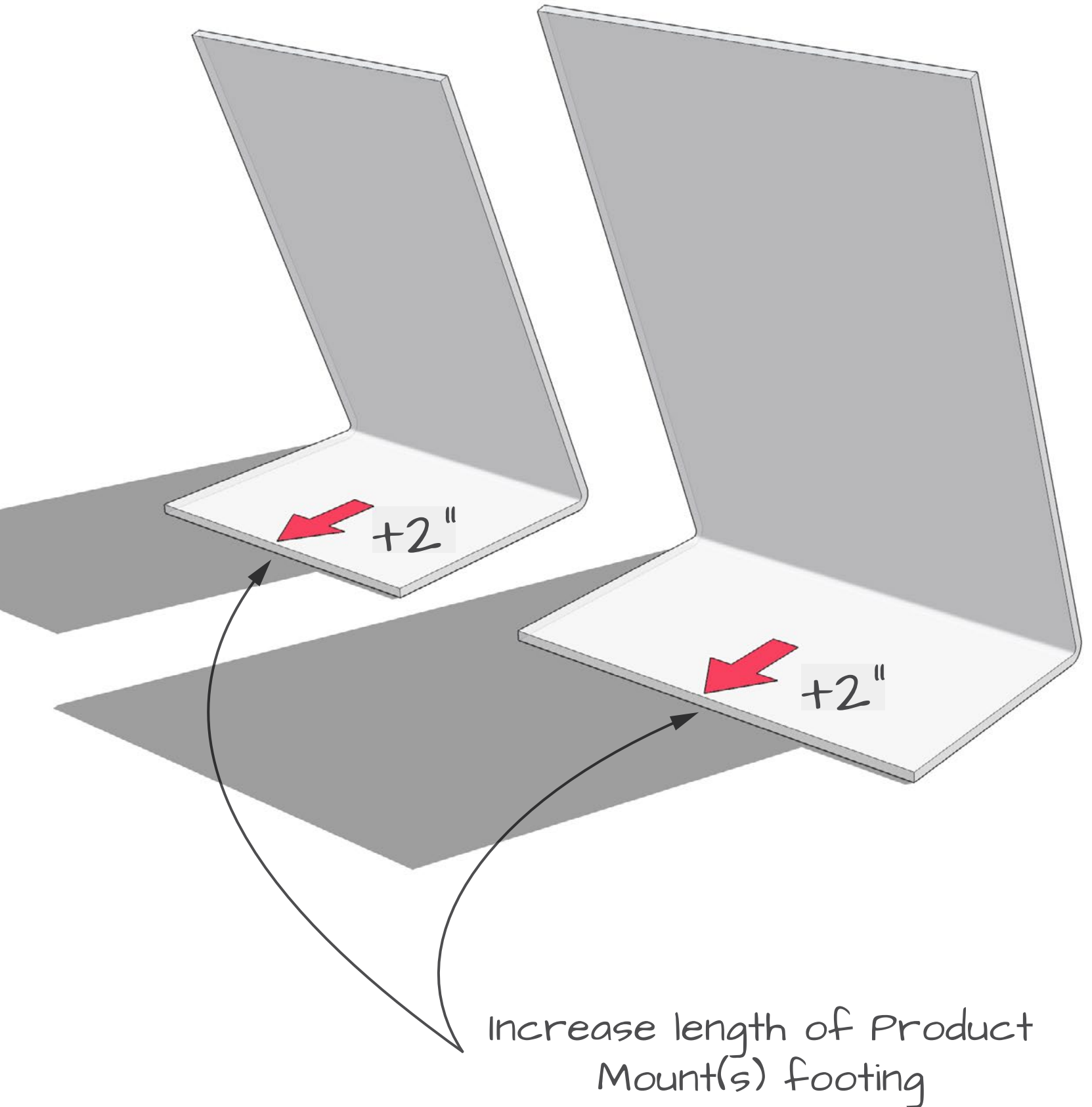

Resize/adjust Base platform as neccessary to accomodate longer Product Mount(s) footing

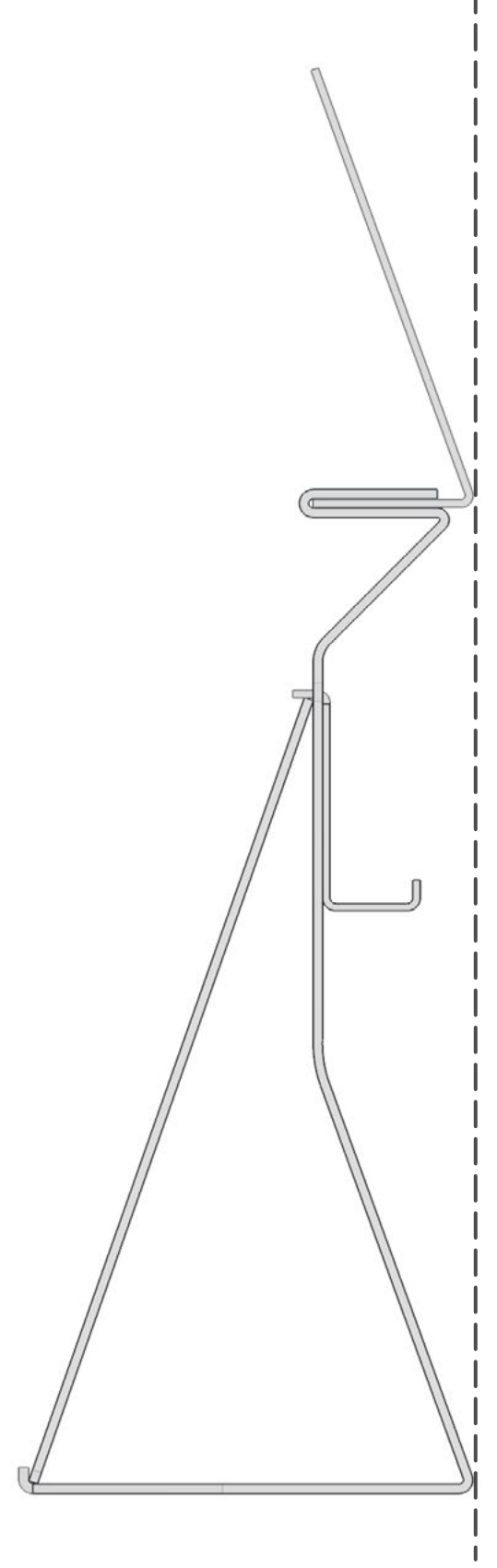

THE GOAL: have the Product Mount not extend past the Base footing.



# PRODUCT MOUNT FRONT

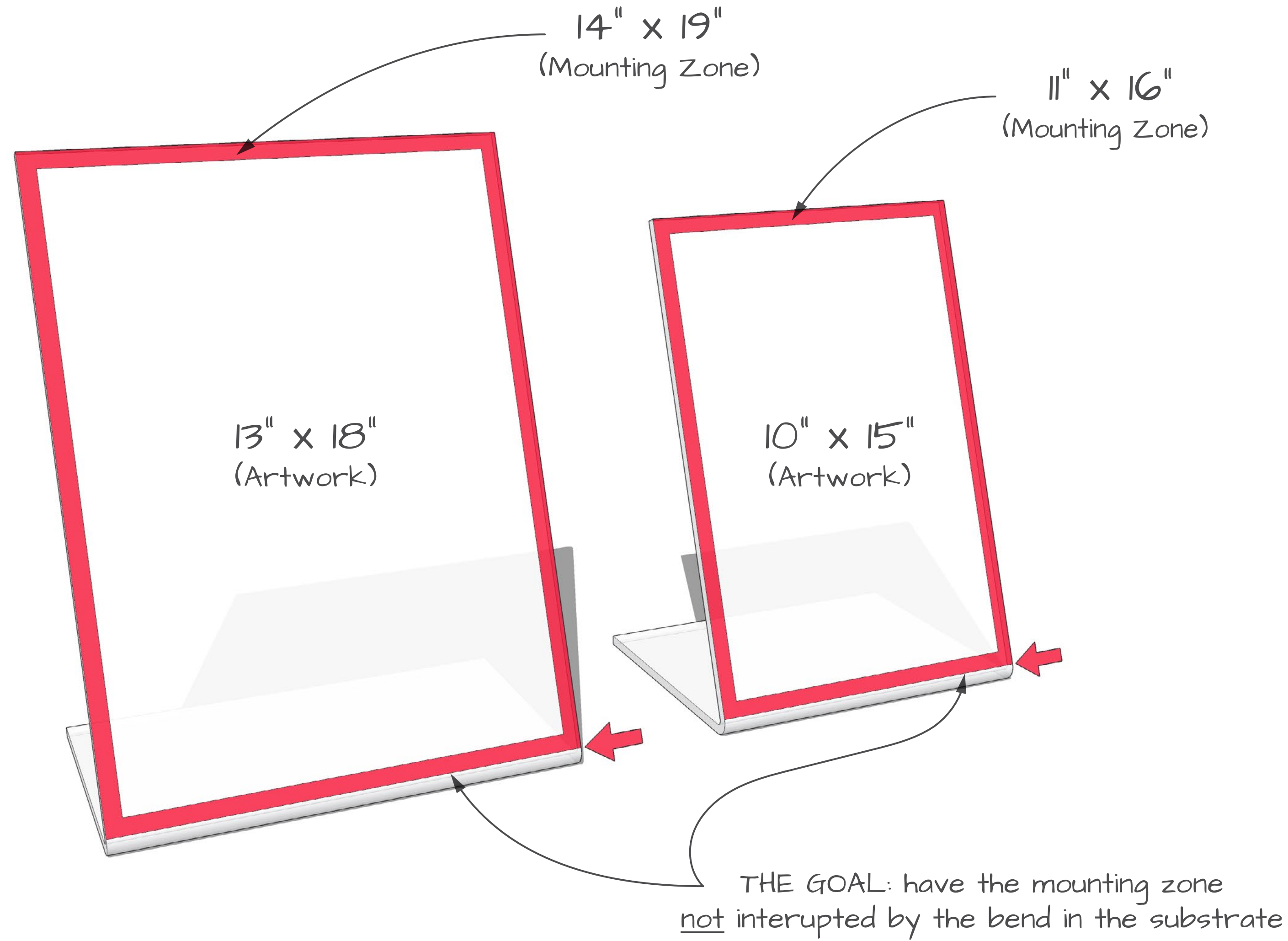



# FINAL DISPLAY

For reference.





## CONTACT

Please don't hesitate to contact me for any reason:

**Ryan Kilthau**

(604) 618-2684

[ryankilthau@icloud.com](mailto:ryankilthau@icloud.com)